

ICC-ES Evaluation Report

ESR-3330

Reissued March 2024

This report also contains:

- CBC Supplement

Subject to renewal March 2025

- LABC Supplement

ICC-ES Evaluation Reports are not to be construed as representing aesthetics or any other attributes not specifically addressed, nor are they to be construed as an endorsement of the subject of the report or a recommendation for its use. There is no warranty by ICC Evaluation Service, LLC, express or implied, as to any finding or other matter in this report, or as to any product covered by the report.

Copyright © 2024 ICC Evaluation Service, LLC. All rights reserved.

<p>DIVISION: 05 00 00—METALS</p> <p>Section: 05 05 27—Metal Connectors</p>	<p>REPORT HOLDER:</p> <p>LINDAPTER</p>	<p>EVALUATION SUBJECT:</p> <p>HOLLO-BOLT® BLIND BOLT FASTENERS</p>	
--	--	--	---

1.0 EVALUATION SCOPE

Compliance with the following codes:

- 2021, 2018, 2015, 2012, and 2009 [International Building Code® \(IBC\)](#)
- 2021, 2018, 2015, 2012, and 2009 [International Residential Code® \(IRC\)](#)
- 2013 *Abu Dhabi International Building Code (ADIBC)*†

†The ADIBC is based on the 2009 IBC. 2009 IBC code sections referenced in this report are the same sections in the ADIBC.

For evaluation for compliance with codes adopted by Los Angeles Department of Building and Safety (LADBS), see [ESR-3330 LABC and LARC Supplement](#).

For evaluation for compliance with codes adopted by the California Department of Health Care Access and Information (HCAI) [also known as the California Office of Statewide Health Planning and Development (OSHPD)] and the Division of State Architects (DSA), see [ESR-3330 CBC and CRC Supplement](#).

Property evaluated:

- Structural

2.0 USES

Hollo-Bolt® Blind Bolt Fasteners are used for connecting structural steel to hollow structural section (HSS) steel members and other structural steel elements where access is difficult or restricted to one side only. Hollo-Bolt® fasteners have been evaluated for resisting tension loads and shear loads in bearing-type connections. The fasteners are alternatives to bolts described in Section J3 of AISC 360, which is referenced in Section 2205.1 of the IBC, for bearing-type connections.

The Hollo-Bolt® Blind Bolt Fasteners are used to resist static loads, wind loads and seismic loads in Seismic Design Categories A through F.

Carbon steel Hollo-Bolt® Fasteners subject to tension or shear loading have been evaluated for fatigue resistance in accordance with Appendix 3 of AISC 360 and may be used in steel connections subject to 10,000 cycles or more of live load application.

The Hollo-Bolt® Blind Bolt Fasteners may be used in structures regulated under the IRC when they are addressed in an engineered design in accordance with IRC Section R301.1.3.

3.0 DESCRIPTION

3.1 General:

Hollo-Bolt[®] Fasteners are assembled from several components. They all have a threaded core bolt, a sleeve and a cone. The sleeve is a steel cylinder with slits which divide the cylinder into segments (legs). The cone is an internally threaded, cone-shaped nut with grooves on the outer surface. After the Hollo-Bolt[®] Fastener is inserted into the aligned holes in the connected steel elements, the core bolt is torqued, causing the cone to move toward the head of the fastener, thereby expanding the legs of the sleeve. The expansion of the sleeve causes the steel elements to be clamped together. See [Figure 1](#) for images describing the typical components of Hollo-Bolt[®] Fasteners.

3.1.1 Hexagonal Head Hollo-Bolt[®] Blind Bolt Fasteners: M08 (⁵/₁₆), M10 (³/₈) and M12 (¹/₂) Hexagonal Head Hollo-Bolt[®] Blind Bolt Fasteners are assembled from three components: the core bolt, a sleeve with an integral collar, and the cone. M16 (⁵/₈) and M20 (³/₄) Hexagonal Head Hollo-Bolt[®] Blind Bolt Fasteners are assembled from five components: the core bolt, a collar, a rubber washer, the sleeve and the cone.

The steel core bolt features a threaded shank and hexagonal head. The collar is a circular element having two flat surfaces (to accommodate an open-ended wrench) with a circular hole. It is intended to bear on the surface of the connected steel member. The sleeve typically has four equally spaced legs, except for the M20 (³/₄) stainless steel fastener, which has eight legs. See [Table 1A](#) for available sizes and lengths, product dimensions and specified clamping thickness ranges. See [Figure 2](#) for typical Hexagonal Head Hollo-Bolt[®] installation.

3.1.2 Countersunk Hollo-Bolt[®] Blind Bolt Fasteners: M08 (⁵/₁₆), M10 (³/₈) and M12 (¹/₂) Countersunk Head Hollo-Bolt[®] Blind Bolt Fasteners are assembled from three components, and M16 (⁵/₈) Countersunk Head Hollo-Bolt[®] Blind Bolt Fasteners are assembled from five components, as described in Section 3.1.1. The core bolt has a countersunk head. The collar must bear on the surface of the connected steel member. The diameter of the collar matches the outside head diameter of the bolt, and the hole in the collar is contoured to receive the countersunk head of the bolt. The bolt head has a recess to allow the use of an Allen wrench to tighten the bolt. See [Table 1B](#) for available sizes, product dimensions and specified clamping thickness ranges. See [Figure 3](#) for typical Countersunk Head Hollo-Bolt[®] installation.

3.1.3 Flush Fit Hollo-Bolt[®] Blind Bolt Fasteners: M08 (⁵/₁₆), M10 (³/₈) and M12 (¹/₂) Flush Fit Hollo-Bolt[®] Blind Bolt Fasteners are assembled from three components: the core bolt, a sleeve and a cone. The core bolt has a countersunk head. The head end of the sleeve is contoured to allow the fastener head to be countersunk into the connected steel element so that the top of the bolt head is flush with the surface of the connected steel. The head end of the sleeve has two notches to receive an installation nut. The bolt head has a recess to allow the use of an Allen wrench to tighten the bolt. See [Table 1C](#) for available sizes, product dimensions and specified clamping thickness ranges. See [Figure 4](#) for typical flush fit head Hollo-Bolt[®] installation.

3.2 Materials:

3.2.1 Carbon Steel Hollo-Bolt[®] Blind Bolt Fasteners:

3.2.1.1 Core Bolt: The hex head core bolt is manufactured from steel complying with EN ISO 898-1, Class 8.8, having a specified tensile strength, F_u , of 116,030 psi (800 MP_a). The core bolt for the Countersunk Head and Flush Fit Head Hollo-Bolt[®] Blind Bolt Fasteners are manufactured from steel complying with EN ISO 898-1, Class 10.9, having F_u of 150,840 psi (1040 MP_a)

3.2.1.2 Sleeve, Collar and Cone: The sleeve, collar and cone components are manufactured from free cutting steel conforming to BS EN 10087 Grade 11SMn30 or 11SMnPb30 or from cold-formed steel complying with SAE 10B21 or EN 10263-4 Grade 20MnB4. The minimum specified tensile strength for the sleeves is 62,400 psi (430 N/mm²) for fastener sizes up to M16 (⁵/₈) and 56,500 psi (390 N/mm²) for M20 (³/₄) fasteners.

3.2.1.3 Coatings: All carbon steel components for a particular part number are coated with the same corrosion-resistant material. Fasteners with hexagonal heads are available with a hot-dip galvanized coating complying with BS EN ISO 1461. Fasteners of all head styles are available with a two-part coating consisting of electroplated zinc and a top coat of JS500 (a proprietary coating); or with a proprietary two-part coating system called Sheraplex.

3.2.2 Stainless Steel Hollo-Bolt[®] Blind Bolt Fasteners: Hollo-Bolt[®] Fasteners of all head styles are available in stainless steel material.

3.2.2.1 Core Bolt: The core bolt is manufactured from stainless steel complying with EN ISO 3506-1, Class A4-70, having a specified tensile strength of 101,500 psi (700 MP_a).

3.2.2.2 Sleeve, Collar and Cone: The sleeve, collar and cone parts are manufactured from stainless steel complying with BS EN 10088-3 Grade X2 CrNiMo 17 12 2. The minimum specified tensile strength for the sleeves is 72,500 psi (500 N/mm²).

3.2.3 Rubber Washer: The shore hardness is measured on the A scale at 80-90.

4.0 DESIGN AND INSTALLATION

4.1 Design:

4.1.1 General: Hollo-Bolt® Fasteners are alternatives to bolts described in Section J3 of AISC 360, which is referenced in Section 2205.1 of the IBC, for bearing-type connections. The design of connections made with the Hollo-Bolt® Fasteners must comply with this report and Section J3 of AISC 360, as applicable. The available tension and shear strengths of the Hollo-Bolt® Fasteners for specific steel thicknesses are shown in [Table 2](#), for both static and seismic loading. Under the tabulated seismic loading, no inelastic deformation of the bolt is expected. Available strengths of the connected steel members are outside the scope of this report and must be determined in accordance with the code.

4.1.2 Requirements for Connected Steel Elements: Holes drilled in the steel elements must have the applicable shape and dimension shown in [Figure 5](#). Spacing requirements to ensure proper installation clearances are also shown in [Figure 5](#). Spacing, end and edge distances for fasteners must also comply with Section J3 of AISC 360 based on the sleeve diameter.

4.1.3 Combined Loading: Combined tension and shear loading on each Hollo-Bolt® Fastener must comply with the following equation:

$$\left(\frac{\text{Tension Demand}}{\text{Tension Capacity}}\right)^2 + \left(\frac{\text{Shear Demand}}{\text{Shear Capacity}}\right)^2 \leq 1.0 \text{ (Eq. 1)}$$

4.1.4 Design for Fatigue: Carbon steel Hollo-Bolt® Fasteners have been evaluated for fatigue resistance when loaded in tension or shear only. Fasteners which are subject to 10,000 or more cycles of live load application must be designed in accordance with Appendix 3 of AISC 360. For Hollo-Bolt® Fasteners subject to tension fatigue, stress category G applies, with $C_f = 0.39$ and $F_{TH} = 7$, determined from Table A-3.1 of AISC 360. For Hollo-Bolt® Fasteners subject to shear fatigue, stress category C applies, with $C_f = 4.4$ and $F_{TH} = 10$, determined from Table A-3.1 of AISC 360. The allowable fatigue loads must be determined in accordance with Equations 2 and 3, as follows:

$$T_{a, fat} = F_{SR,t} * A_{eb} * R_{b,t} \text{ (Eq. 2)}$$

$$V_{a, fat} = F_{SR,v} * A_{eb} * R_{b,v} \text{ (Eq. 3)}$$

where:

$F_{SR,(t \text{ or } v)}$	=	Applicable allowable stress range determined in accordance with Equation A-3-1 of AISC 360, ksi
A_{eb}	=	Cross-sectional area of the bolt at the root diameter, in ² (See Table 3)
$R_{b,t}$	=	Factor relating static tension load performance of a Hollo-Bolt® to the allowable static tension strength of the core bolt. (See Table 3)
$R_{b,v}$	=	Factor accounting for: 1) static shear load performance of a Hollo-Bolt® relative to the allowable static shear strength of the core bolt; and 2) fatigue test conditions relative to typical Hollo-Bolt® installation. (See Table 3)

4.2 Installation:

The Hollo-Bolt® Fasteners must be installed in accordance with the details noted in this section, the manufacturer’s published installation instructions and the approved plans. The manufacturer’s published installation instructions and the approved plans must be available at the jobsite at all times during installation. The report holder’s published installation instructions must be included in the packages of Hollo-Bolt® Fasteners.

See [Figure 6](#) for a depiction of the typical installation sequence. The required installation procedures and sequence are as follows:

1. Holes complying with Section 4.1.2 and the approved plans must be drilled into the steel members which are to be connected.
2. Burrs in the holes must be removed before insertion of the Hollo-Bolt[®] Fasteners.
3. The structural steel elements which will be connected must be positioned to ensure the following:
 - a. The two sections are lined up and rest one against the other without any gap. Clamps must be used as necessary to hold the two sections together and prevent formation of gaps.
 - b. The holes are aligned, using a mandrel if necessary.
4. The Hollo-Bolt[®] Fasteners must be positioned in the holes. For Hexagonal Head and Countersunk Head fasteners, the collar must rest flat against the section with no gap. For Flush Fit Head fasteners, the head of the fastener must be flush with the surface of the steel element.
5. For Hexagonal Head and Countersunk Head fasteners, the collar must be held in position using a suitable open-ended wrench, and then the core bolt must be tightened to the specified torque shown below.

Hollo-Bolt [®] Fastener Size	Tightening Torque (ft-lbf)
M08 (⁵ / ₁₆)	17
M10 (³ / ₈)	33
M12 (¹ / ₂)	59
M16 (⁵ / ₈)	140
M20 (³ / ₄)	221

For SI: 1 inch = 25.4 mm, 1 ft-lbf = 1.36 N-m.

6. For the Flush Fit Head fasteners, an installation nut is placed over the head of the fastener and keyed into the notches in the collar. The installation nut must be held in position using a suitable open-ended wrench. An Allen wrench is inserted through the hole in the installation nut, into the recess in the fastener head, whereby the bolt is tightened to the specified torque, which is the same as for Hexagonal Head fasteners.
7. The tightening tools must then be removed and the tightening torque on the bolt must be verified. If necessary, the tightening torque must be corrected.

4.3 Special Inspection:

Special inspection is required in accordance with IBC Sections 1704.3, 1705.1.1 and 1705.2 (2009 IBC Sections 1704.3, 1704.15 and 1705). Lindapter must submit procedures for verifying proper installation of the Hollo-Bolt[®] to the inspector. Where Hollo-Bolt[®] Fasteners are used for seismic or wind load resistance, special inspection requirements must comply with 2021 IBC Sections 1705.12, 1705.13 and 1705.14 (2018 and 2015 IBC Sections 1705.11, 1705.12 and 1705.13; 2012 IBC Sections 1705.10, 1705.11 and 1705.12; 2009 IBC Sections 1706, 1707 and 1708), as applicable.

5.0 CONDITIONS OF USE:

The Hollo-Bolt[®] Blind Bolt Fasteners described in this report comply with, or are suitable alternatives to what is specified in, the code noted in Section 1.0 of this report, subject to the following conditions:

- 5.1 Calculations and details showing that the connections made with the Hollo-Bolt[®] Fasteners are capable of resisting the applied loads must be submitted to the code official for approval, taking into account the strength of the Hollo-Bolt[®] Fasteners and the strength of the connected steel elements. The calculations and details must be signed and sealed by a registered design professional, when required by the statutes of the jurisdiction in which the project is to be constructed.
- 5.2 Fire-resistive construction: Where not otherwise prohibited in the code, Hollo-Bolt[®] Fasteners are permitted for use with fire-resistance-rated construction provided that at least one of the following conditions is fulfilled:
 - The Hollo-Bolt[®] Fasteners are used to resist wind or seismic forces or fatigue loading only.
 - Hollo-Bolt[®] Fasteners that support a fire-resistance-rated envelope or a fire-resistance-rated membrane, are protected by approved fire-resistance-rated materials or have been evaluated for resistance to fire exposure in accordance with recognized standards.
 - The Hollo-Bolt[®] Fasteners are used to support nonstructural elements.
- 5.3 Special inspection must be provided as specified in Section 4.3 of this report.
- 5.4 Use of the Hollo-Bolt[®] Fasteners in applications where the applicable code requires slip-critical installation, is beyond the scope of this report.

5.5 The Hollo-Bolt[®] Blind Bolt Fasteners are manufactured under a quality control program with inspections by ICC-ES.

6.0 EVIDENCE SUBMITTED

Data in accordance with the [ICC-ES Acceptance Criteria for Expansion Bolts in Structural Steel Connections \(AC437\)](#), dated June 2022.

7.0 IDENTIFICATION

- 7.1 The ICC-ES mark of conformity, electronic labeling, or the evaluation report number (ICC-ES ESR-3330) along with the name, registered trademark, or registered logo of the report holder must be included in the product label.
- 7.2 In addition, packages of Hollo-Bolt[®] fasteners must be labeled with the product name (Hollo-Bolt[®]), the product part number, quantity, batch number and an image of the product. The fastener is identified by an eight-character part number (LHBMXX#XHDG). The first three letters (LHB) indicate it is a Lindapter Hollo-Bolt[®], the next three characters denote the Hollo-Bolt[®] size (for example M08) and the last two digits indicate the length of the Hollo-Bolt[®] (for example #1, #2 or #3).
- 7.3 The report holder’s contact information is the following:

LINDAPTER
LINDSAY HOUSE BRACKENBECK ROAD
BRADFORD, WEST YORKSHIRE BD7 2NF
UNITED KINGDOM
+44(0) 1274 521444
www.lindapter.com
www.lindapterusa.com



FIGURE 1—TYPICAL HOLLO-BOLT[®] FASTENER COMPONENTS
(Hexagonal Head Fastener Shown)

TABLE 1A—HEXAGONAL HEAD HOLLO-BOLT[®] FASTENER DIMENSIONS

PART NUMBER				DIMENSIONAL INFORMATION					SPECIFIED CLAMPING RANGE, W (inches)	
Zinc + JS500	Hot-dip Galvanized	Sheraplex	Stainless Steel	Nominal Hollo-Bolt [®] Size, Z	Sleeve Diameter, S (in.)	Bolt Length Below Collar, B (in.)	Across Flats of Bolt Head (in.)	Across Flats of Collar A/F (in.)	Min.	Max.
LHBM08HEX#1ZN	LHBM08HEX#1HDG	LHBM08HEX#1SP	LHBM08HEX#1ST	M08 (⁵ / ₁₆) Size 1	0.541	1 ³ / ₄	1/2	3/4	1/4	7/8
LHBM08HEX#2ZN	LHBM08HEX#2HDG	LHBM08HEX#2SP	M08 (⁵ / ₁₆) Size 2	2 ⁹ / ₁₆		7/8			1 ⁵ / ₈	
LHBM08HEX#3ZN	LHBM08HEX#3HDG	LHBM08HEX#3SP	M08 (⁵ / ₁₆) Size 3	3 ³ / ₈		1 ⁵ / ₈			2 ³ / ₈	
LHBM10HEX#1ZN	LHBM10HEX#1HDG	LHBM10HEX#1SP	LHBM10HEX#1ST	M10 (³ / ₈) Size 1	0.699	2	5/8	15/16	5/16	7/8
LHBM10HEX#2ZN	LHBM10HEX#2HDG	LHBM10HEX#2SP	M10 (³ / ₈) Size 2	2 ¹ / ₂		7/8			1 ⁵ / ₈	
LHBM10HEX#3ZN	LHBM10HEX#3HDG	LHBM10HEX#3SP	M10 (³ / ₈) Size 3	3 ⁵ / ₁₆		1 ⁵ / ₈			2 ³ / ₈	
LHBM12HEX#1ZN	LHBM12HEX#1HDG	LHBM12HEX#1SP	LHBM12HEX#1ST	M12 (1/2) Size 1	0.778	2 ¹ / ₈	1 1/16	1 3/16	5/16	1
LHBM12HEX#2ZN	LHBM12HEX#2HDG	LHBM12HEX#2SP	M12 (1/2) Size 2	2 ⁷ / ₈		1			1 ¹³ / ₁₆	
LHBM12HEX#3ZN	LHBM12HEX#3HDG	LHBM12HEX#3SP	M12 (1/2) Size 3	3 ³ / ₄		1 ¹³ / ₁₆			2 ³ / ₄	
LHBM16HEX#1ZN	LHBM16HEX#1HDG	LHBM16HEX#1SP	LHBM16HEX#1ST	M16 (⁵ / ₈) Size 1	1.01	2 ⁵ / ₈	1 ⁵ / ₁₆	1 ⁷ / ₁₆	1/2	1 ¹ / ₈
LHBM16HEX#2ZN	LHBM16HEX#2HDG	LHBM16HEX#2SP	M16 (⁵ / ₈) Size 2	3 ⁵ / ₈		1 ¹ / ₈			2	
LHBM16HEX#3ZN	LHBM16HEX#3HDG	LHBM16HEX#3SP	M16 (⁵ / ₈) Size 3	4 ⁷ / ₁₆		2			2 ¹³ / ₁₆	
LHBM20HEX#1ZN	LHBM20HEX#1HDG	LHBM20HEX#1SP	LHBM20HEX#1ST	M20 (³ / ₄) Size 1	1.29	3 ¹ / ₈	1 ³ / ₁₆	1 ¹³ / ₁₆	1/2	1 ⁵ / ₁₆
LHBM20HEX#2ZN	LHBM20HEX#2HDG	LHBM20HEX#2SP	M20 (³ / ₄) Size 2	4 ⁵ / ₁₆		1 ⁵ / ₁₆			2 ³ / ₈	
LHBM20HEX#3ZN	LHBM20HEX#3HDG	LHBM20HEX#3SP	M20 (³ / ₄) Size 3	5 ¹ / ₂		2 ³ / ₈			3 ³ / ₈	

For SI: 1 inch = 25.4 mm.

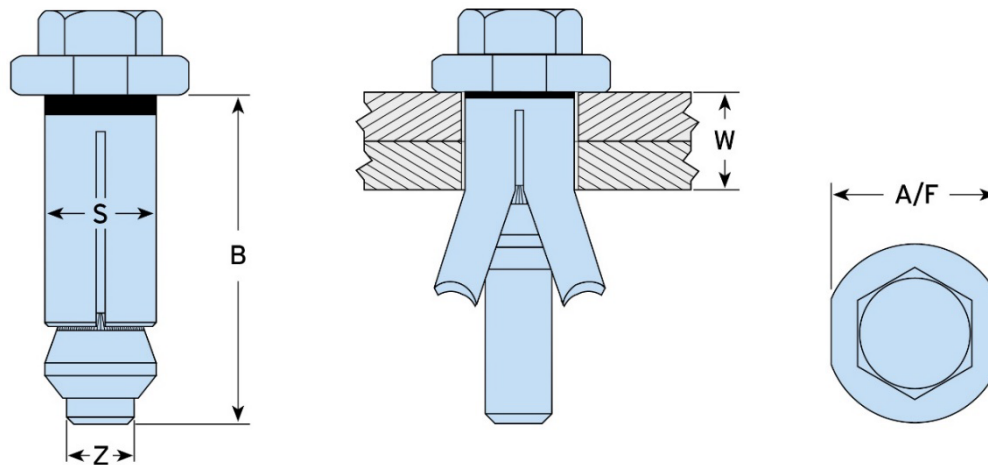

FIGURE 2—HEXAGONAL HEAD HOLLO-BOLT[®]

TABLE 1B—COUNTERSUNK HEAD HOLLO-BOLT[®] FASTENER DIMENSIONS

PART NUMBER			DIMENSIONAL INFORMATION (inches)					SPECIFIED CLAMPING RANGE, W (inches)	
Zinc + JS500	Sheraplex	Stainless Steel	Nominal Hollo-Bolt [®] Size, Z	Sleeve Diameter, S (in.)	Bolt Length Below Collar, B (in.)	Bolt Head Recess	Across Flats of Collar, A/F (in.)	Min.	Max.
LHBM08CSK#1ZN	LHBM08CSK#1SP	LHBM08CSK#1ST	M08 (⁵ / ₁₆) Size 1	0.541	1 ³ / ₄	Allen 5 mm	3/4	1/4	7/8
LHBM08CSK#2ZN	LHBM08CSK#2SP	LHBM08CSK#2ST	M08 (⁵ / ₁₆) Size 2		2 ⁹ / ₁₆			7/8	1 ⁵ / ₈
LHBM08CSK#3ZN	LHBM08CSK#3SP	LHBM08CSK#3ST	M08 (⁵ / ₁₆) Size 3		3 ³ / ₈			1 ⁵ / ₈	2 ³ / ₈
LHBM10CSK#1ZN	LHBM10CSK#1SP	LHBM10CSK#1ST	M10 (³ / ₈) Size 1	0.699	1 ³ / ₄	Allen 6 mm	1 ⁵ / ₁₆	5/16	7/8
LHBM10CSK#2ZN	LHBM10CSK#2SP	LHBM10CSK#2ST	M10 (³ / ₈) Size 2		2 ¹ / ₂			7/8	1 ⁵ / ₈
LHBM10CSK#3ZN	LHBM10CSK#3SP	LHBM10CSK#3ST	M10 (³ / ₈) Size 3		3 ⁵ / ₁₆			1 ⁵ / ₈	2 ³ / ₈
LHBM12CSK#1ZN	LHBM12CSK#1SP	LHBM12CSK#1ST	M12 (¹ / ₂) Size 1	0.778	1 ⁷ / ₈	Allen 8 mm	1 ³ / ₁₆	5/16	1
LHBM12CSK#2ZN	LHBM12CSK#2SP	LHBM12CSK#2ST	M12 (¹ / ₂) Size 2		2 ⁷ / ₈			1	1 ¹³ / ₁₆
LHBM12CSK#3ZN	LHBM12CSK#3SP	LHBM12CSK#3ST	M12 (¹ / ₂) Size 3		3 ¹¹ / ₁₆			1 ¹³ / ₁₆	2 ³ / ₄
LHBM16CSK#1ZN	LHBM16CSK#1SP	LHBM16CSK#1ST	M16 (⁵ / ₈) Size 1	1.01	2 ⁷ / ₁₆	Allen 10 mm	1 ⁷ / ₈	1/2	1 ¹ / ₈
LHBM16CSK#2ZN	LHBM16CSK#2SP	LHBM16CSK#2ST	M16 (⁵ / ₈) Size 2		3 ⁵ / ₈			1 ¹ / ₈	2
LHBM16CSK#3ZN	LHBM16CSK#3SP	LHBM16CSK#3ST	M16 (⁵ / ₈) Size 3		4 ⁷ / ₁₆			2	2 ¹³ / ₁₆

For SI: 1 inch = 25.4 mm.

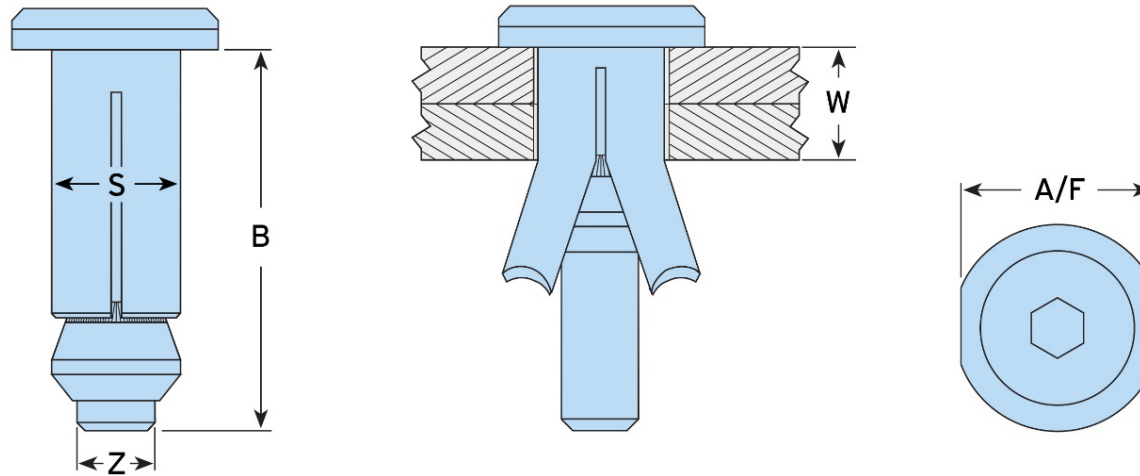

FIGURE 3—COUNTERSUNK HEAD HOLLO-BOLT[®]

TABLE 1C—FLUSH FIT HEAD HOLLO-BOLT[®] FASTENER DIMENSIONS

PART NUMBER			DIMENSIONAL INFORMATION (inches)					SPECIFIED CLAMPING RANGE, W (inches)	
Zinc + JS500	Sheraplex	Stainless Steel	Nominal Hollo-Bolt [®] Size, Z	Sleeve Diameter, S (in.)	Bolt Length from Top of Head, B (in.)	Bolt Head Recess	Across Flats of Installation Nut A/F (in.)	Min.	Max.
LHBM08FF#1ZN	LHBM08FF#1SP	LHBM08FF#1ST	M08 (⁵ / ₁₆) Size 1	0.541	2	Allen 5 mm	³ / ₄	³ / ₈	1 ¹ / ₁₆
LHBM08FF#2ZN	LHBM08FF#2SP	LHBM08FF#2ST	M08 (⁵ / ₁₆) Size 2		2 ³ / ₄			1 ¹ / ₁₆	1 ³ / ₄
LHBM08FF#3ZN	LHBM08FF#3SP	LHBM08FF#3ST	M08 (⁵ / ₁₆) Size 3		3 ⁹ / ₁₆			1 ³ / ₄	2 ¹ / ₂
LHBM10FF#1ZN	LHBM10FF#1SP	LHBM10FF#1ST	M10 (³ / ₈) Size 1	0.699	2	Allen 6 mm	¹⁵ / ₁₆	¹ / ₂	1 ¹ / ₁₆
LHBM10FF#2ZN	LHBM10FF#2SP	LHBM10FF#2ST	M10 (³ / ₈) Size 2		2 ³ / ₄			1 ¹ / ₁₆	1 ³ / ₄
LHBM10FF#3ZN	LHBM10FF#3SP	LHBM10FF#3ST	M10 (³ / ₈) Size 3		3 ⁹ / ₁₆			1 ³ / ₄	2 ¹ / ₂
LHBM12FF#1ZN	LHBM12FF#1SP	LHBM12FF#1ST	M12 (¹ / ₂) Size 1	0.778	2 ³ / ₁₆	Allen 8 mm	¹ / ₂	¹ / ₂	1 ³ / ₁₆
LHBM12FF#2ZN	LHBM12FF#2SP	LHBM12FF#2ST	M12 (¹ / ₂) Size 2		3 ¹ / ₈			1 ³ / ₁₆	2 ¹ / ₃₂
LHBM12FF#3ZN	LHBM12FF#3SP	LHBM12FF#3ST	M12 (¹ / ₂) Size 3		4			2 ¹ / ₃₂	2 ⁷ / ₈

For SI: 1 inch = 25.4 mm.

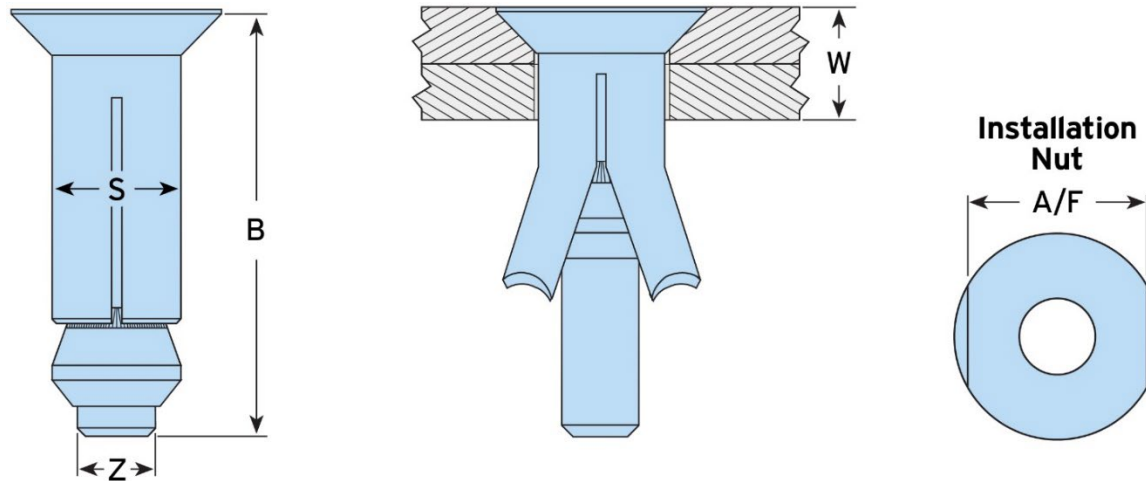

FIGURE 4—FLUSH-FIT HEAD HOLLO-BOLT[®]

TABLE 2—AVAILABLE TENSION AND SHEAR STRENGTHS FOR HOLLO-BOLT[®] FASTENERS

HOLLO-BOLT [®] FASTENER SIZE (inch)	AVAILABLE STATIC AND WIND LOADS (lbf)				AVAILABLE SEISMIC LOADS (lbf)			
	LRFD Method		ASD Method		LRFD Method		ASD Method	
	Tensile ¹	Shear ²	Tensile ¹	Shear ²	Tensile ¹	Shear ²	Tensile ¹	Shear ²
Carbon Steel Hollo-Bolt[®] Fasteners (All head styles, all finishes)								
M08 (5/16)	3,780	3,220	2,340	2,000	3,310	2,680	2,045	1,670
M10 (3/8)	6,160	5,490	3,820	3,420	5,490	4,570	3,400	2,830
M12 (1/2)	8,550	7,490	5,310	4,680	7,470	6,250	4,630	3,890
M16 (5/8)	13,900	11,600	8,640	7,290	13,300	9,780	8,270	6,090
M20 (3/4)	20,000	18,400	12,400	11,500	19,400	15,300	12,000	9,560
Stainless Steel Hollo-Bolt[®] Fasteners (All head styles)								
M08 (5/16)	5,980	6,430	3,730	4,020	4,790	4,770	2,990	2,970
M10 (3/8)	9,730	10,930	6,070	6,830	8,120	9,220	5,080	5,760
M12 (1/2)	12,190	13,440	7,620	8,430	10,250	12,250	6,410	7,640
M16 (5/8)	15,270	17,330	9,530	10,840	13,130	15,200	8,210	9,490
M20 (3/4)	23,040	26,750	14,410	16,700	19,510	25,850	12,190	16,140

For SI: 1 inch = 25.4 mm, 1 lbf = 4.45 N.

¹The tabulated **tension** values have been determined using the plate thicknesses shown below, which caused failure of the Hollo-Bolt[®] Fastener itself. Connection strength for thinner plates should be checked for applicable limit states.

Fastener Material	Plate Thickness for Hex Head and Countersunk Head Tension Connections (inch)					Plate Thickness for Flush Fit Head Tension Connections (inch)		
	M08	M10	M12	M16	M20	M08	M10	M12
Carbon Steel	0.433	0.433	0.492	0.551	0.669	0.394	0.394	0.394
Stainless Steel	0.394	0.394	0.394	0.472	0.591	0.394	0.394	0.394

²The tabulated **shear** values have been determined using the plate thicknesses shown below, which caused failure of the Hollo-Bolt[®] Fastener itself. Connection strength for thinner plates should be checked for applicable limit states.

Fastener Material	Applicable Ply	Plate Thickness for Hex Head and Countersunk Head Shear Connections (inch)					Plate Thickness for Flush Fit Head Shear Connections (inch)		
		M08	M10	M12	M16	M20	M08	M10	M12
Carbon Steel or Stainless Steel	Outer Ply (toward head)	0.236	0.315	0.315	0.394	0.472	0.315	0.394	0.394
	Inner Ply (toward nut)	0.236	0.315	0.315	0.394	0.472	0.236	0.315	0.315

TABLE 3—VALUES FOR USE IN FATIGUE DESIGN

Hollo-Bolt [®] Fastener Size	A _{eb} (in ²) ¹	R _{b,t}	R _{b,v}
M08 (5/16)	0.057	0.70	0.40
M10 (3/8)	0.090		
M12 (1/2)	0.131		
M16 (5/8)	0.243		
M20 (3/4)	0.380		

For SI: 1 in² = 645 mm².

¹Determined at the minor thread (root) diameter

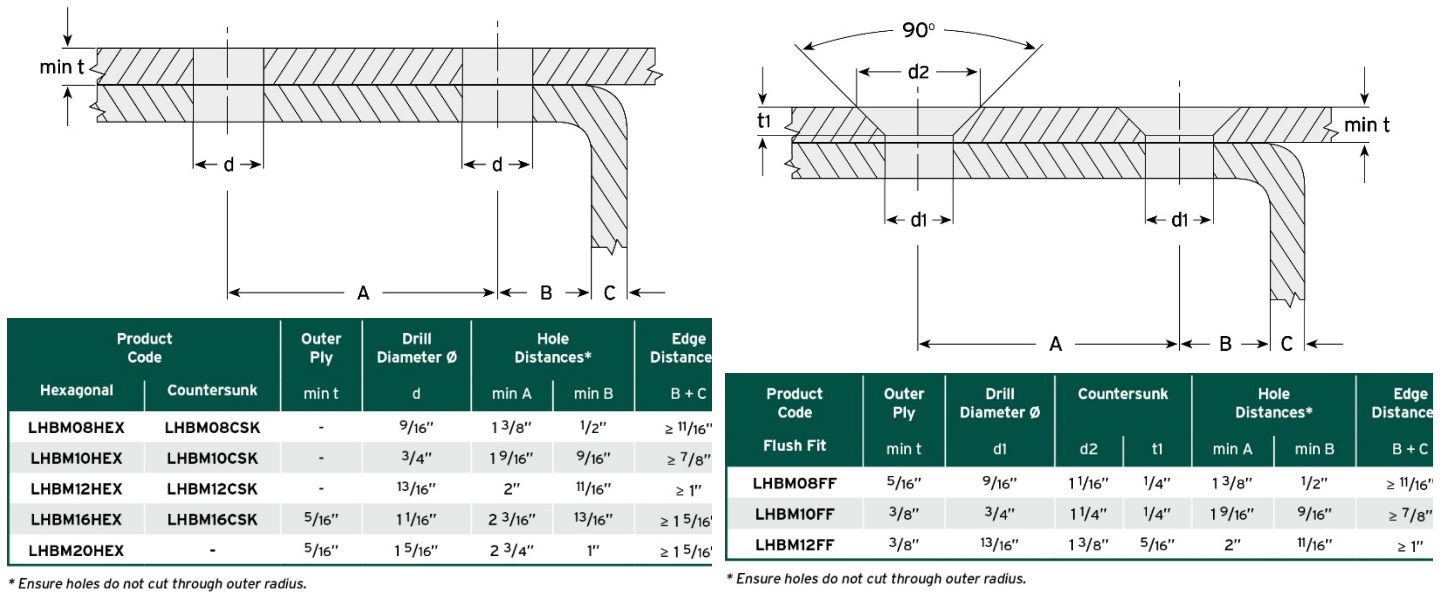

For Hexagonal Head and Countersunk Head Hollo-Bolt[®] Fasteners

For Flush Fit Head Hollo-Bolt[®] Fasteners

FIGURE 5—MINIMUM CONNECTION GEOMETRY REQUIREMENTS FOR HOLLO-BOLT[®] FASTENERS

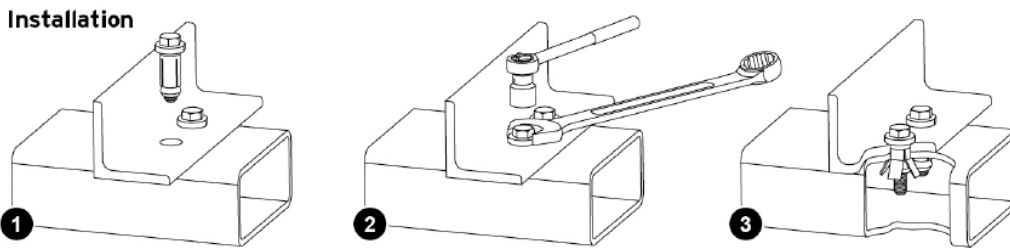

FIGURE 6—HOLLO-BOLT[®] FASTENER INSTALLATION PROCEDURE (Hexagonal Head Fastener Shown)

DIVISION: 05 00 00—METALS
Section: 05 05 27—Metal Connectors

REPORT HOLDER:

LINDAPTER

EVALUATION SUBJECT:

HOLLO-BOLT® BLIND BOLT FASTENERS

1.0 REPORT PURPOSE AND SCOPE**Purpose:**

The purpose of this evaluation report supplement is to indicate that Hollo-Bolt® Blind Bolt Fasteners, described in ICC-ES evaluation report [ESR-3330](#), have also been evaluated for compliance with the codes noted below as adopted by the Los Angeles Department of Building and Safety (LADBS).

Applicable code editions:

- 2023 *City of Los Angeles Building Code* (LABC)
- 2023 *City of Los Angeles Residential Code* (LARC)

2.0 CONCLUSIONS

The Hollo-Bolt® Blind Bolt Fasteners, described in Sections 2.0 through 7.0 of the evaluation report [ESR-3330](#), comply with the LABC Chapter 22, and the LARC, and are subject to the conditions of use described in this supplement.

3.0 CONDITIONS OF USE

The Hollo-Bolt® Blind Bolt Fasteners described in this evaluation report supplement must comply with all of the following conditions:

- All applicable sections in the evaluation report [ESR-3330](#).
- The design, installation, conditions of use and identification of the Hollo-Bolt® Blind Bolt Fasteners are in accordance with the 2021 *International Building Code*® (IBC) provisions noted in the evaluation report [ESR-3330](#).
- The design, installation and inspection are in accordance with additional requirements of LABC Chapters 16, 17 and 22, as applicable.
- Under the LARC, an engineered design in accordance with LARC Section R301.1.3 must be submitted.

This supplement expires concurrently with the evaluation report, reissued March 2024.

DIVISION: 05 00 00—METALS

Section: 05 05 27—Metal Connectors

REPORT HOLDER:

LINDAPTER

EVALUATION SUBJECT:

HOLLO-BOLT® BLIND BOLT FASTENERS

1.0 REPORT PURPOSE AND SCOPE

Purpose:

The purpose of this evaluation report supplement is to indicate that Hollo-Bolt® Blind Bolt Fasteners described in ICC-ES evaluation report ESR-3330, have also been evaluated for compliance with the code(s) noted below.

Applicable code edition(s):

- 2022 California Building Code (CBC)

For evaluation of applicable Chapters adopted by the California Office of Statewide Health Planning and Development (OSHPD) AKA: California Department of Health Care Access and Information (HCAI) and the Division of State Architect (DSA), see Sections 2.1.1 and 2.1.2 below.

- 2022 California Residential Code (CRC)

2.0 CONCLUSIONS

2.1 CBC:

The Hollo-Bolt® Blind Bolt Fasteners, described in Sections 2.0 through 7.0 of the evaluation report ESR-3330, comply with CBC Chapters 22, provided the design and installation are in accordance with the 2021 *International Building Code*® (IBC) provisions noted in the evaluation report and the additional requirements of Chapters 16 and 17, as applicable.

2.1.1 OSHPD:

The Hollo-Bolt® Blind Bolt Fasteners, described in Sections 2.0 through 7.0 of the evaluation report ESR-3330, comply with CBC Chapter 22 and applicable amendments and Chapter 22A, provided the design and installation are in accordance with the 2021 IBC provisions noted in the evaluation report and the additional requirements in Sections 2.1.1.1 and 2.1.1.2 of this supplement:

2.1.1.1 Verification Test Requirements: The installation verification tests shall be in accordance with Section 2213.1 [OSHPD 1R, 2 & 5] or 2213A.1 [OSHPD 1 & 4] of the CBC, as applicable.

2.1.1.2 Special Inspection Requirements: The special inspection shall be in accordance with Section 1705.2.6 [OSHPD 1R, 2 & 5] or 1705A.2.6 [OSHPD 1 & 4] of the CBC, as applicable.

2.1.2 DSA:

The Hollo-Bolt® Blind Bolt Fasteners, described in Sections 2.0 through 7.0 of the evaluation report ESR-3330, comply with CBC Chapter 22 and applicable amendments and Chapter 22A, provided the design and installation are in accordance with the 2021 IBC provisions noted in the evaluation report and the additional requirements in Sections 2.1.2.1 and 2.1.2.2 of this supplement:

2.1.2.1 Verification Test Requirements: The installation verification tests shall be in accordance with Section 2212.6.1 [DSA-SS/CC] or 2213A.1 [DSA-SS] of the CBC and DSA IR-17-8, as applicable.

2.1.2.2 Special Inspection Requirements: The special inspections shall be in accordance with Section 1705A.2.6 [DSA-SS/CC and DSA-SS] of the CBC and DSA IR-17-9, as applicable.

2.2 CRC:

The Hollo-Bolt® Blind Bolt Fasteners, described in Sections 2.0 through 7.0 of the evaluation report ESR-3330, comply with the CRC, provided the design and installation are in accordance with the 2021 *International Residential Code*® (IRC) provisions noted in the evaluation report.

This supplement expires concurrently with the evaluation report, reissued March 2024.



Special Inspection Document

For compliance with ICC-ES ESR-3330

Ref: SIDHB_MAR24



This document applies to all Hollo-Bolts in all corrosion protection options, as per ESR-3330.

To verify correct installation including use in seismic, wind and fatigue loading applications in accordance with the 2012, 2015, 2018 and 2021 International Building Code, please refer to the following instructions.

Inspection prior to installation...

- Ensure that there are no gaps between the connecting steelwork.
- Ensure that the holes are aligned and that the holes have the correct diameter and spacing for the chosen Hollo-Bolt.
- The holes must be standard diameter holes conforming to AISC 360 where the hole diameter must be no greater than the sleeve outer diameter + 1/16". Please refer to Lindapter's installation instruction sheet for the correct drill bit sizes.
- Burrs in the holes must be removed before insertion of the Hollo-Bolt.

Inspection during installation...

- Ensure that the Hollo-Bolts are installed as per Lindapter's installation instruction sheet.
- Ensure that the torque wrench(s) has a current valid calibration certificate and is calibrated on a regular basis.
- If using air powered wrenches to tighten the Hollo-Bolt, check that the wrench is set correctly to avoid overtightening. The final torque must be checked with a calibrated torque wrench.
- If after tightening there is a gap evident between the Hollo-Bolt and the contact surface of the connecting element this may indicate incorrect installation. Remove and discard the Hollo-Bolt, realign the connecting steelwork and install a new Hollo-Bolt as per Lindapter's installation instruction sheet.
- If after tightening the bolt head continues to turn this may be an indication of overtightening, remove and discard the Hollo-Bolt and install a new Hollo-Bolt as per Lindapter's installation instruction sheet.

Inspection after installation...

- Ensure that there are no gaps between the connecting steelwork.
- Ensure that there are no gaps between the Hollo-Bolt and the contact surface of the connecting element.
- Check the tightening torque of between 5-10% of the installed Hollo-Bolts chosen at random using a calibrated torque wrench.
- If period checks are required, it is recommended that the tightening torque of between 5-10% of the installed Hollo-Bolts chosen at random are checked using a calibrated torque wrench.