

Type LC

A flange clamp with tapped holes to accept threaded rod or cable clips. Supplied with a high tensile cup point setscrew for parallel or tapered flanges.

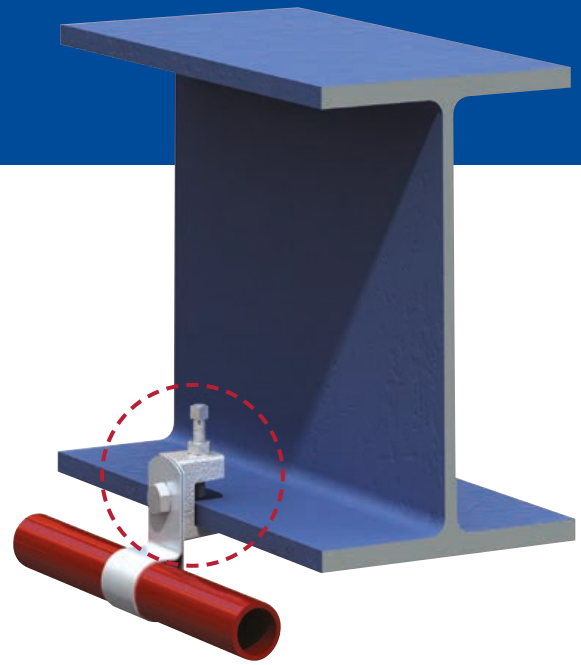
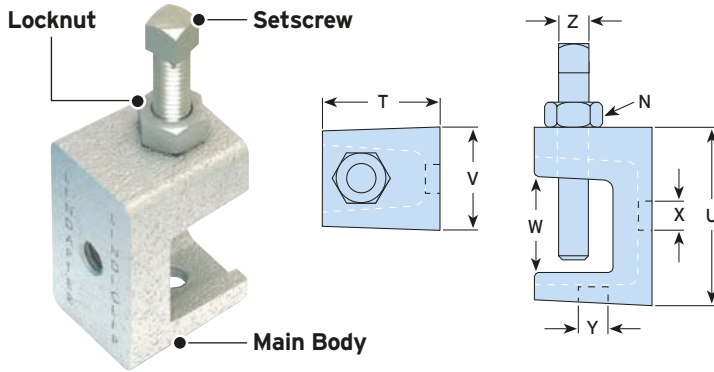

Material: Malleable iron, zinc plated.

Product Code	Thread		Safe Working Load (4:1 Factor of Safety)		Clamping Range W	Setscrew* Z	Tightening Torque		Dimensions		
	X	Y	Tensile in Position X lbs	Tensile in Position Y lbs			Setscrew Z ft lb	Locknut N ft lb	T	U	Width V
LLC025	1/4" UNC	1/4" UNC	40	135	1/8" - 13/16"	M6 (1/4")	3	3	1"	17/16"	7/8"

* Metric setscrew supplied.

➔ Installation is the same as Type FL (page 52).

Type SW

A swivel unit for applications on inclined beams complete with a M10 (3/8" x 3 9/16") Grd. 5 setscrew and nut. Can be supplied with Type FL.

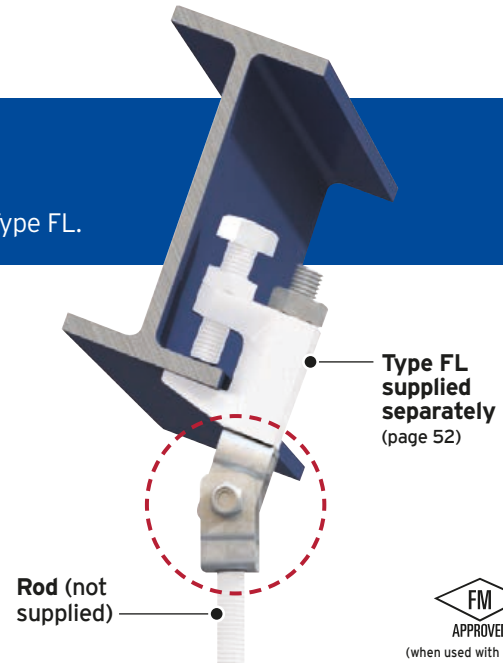
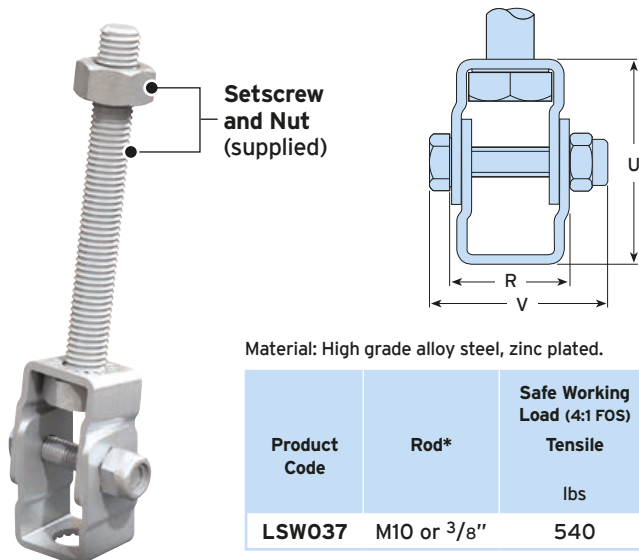

Material: High grade alloy steel, zinc plated.

Product Code	Rod*	Safe Working Load (4:1 FOS)		Rotation	Tightening Torque ft lb	Dimensions		
		Tensile lbs	Maximum Inclination			U	R	Width with Bolt V
LSW037	M10 or 3/8"	540	18°	360°	8	13/4"	1"	13/8"

* Secure threaded rod (either M10 or 3/8") to the Type SW using a standard nut.

