

# Type F3

An FM approved, high strength flange clamp with a large clamping range.

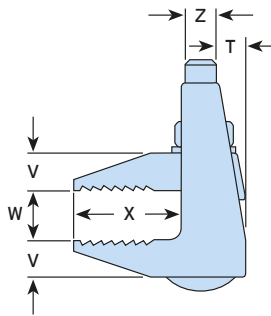

For heavier loads or wider clamping range, please see the Type F9 on page 23.

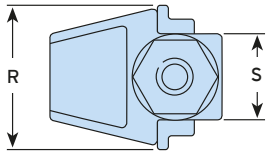
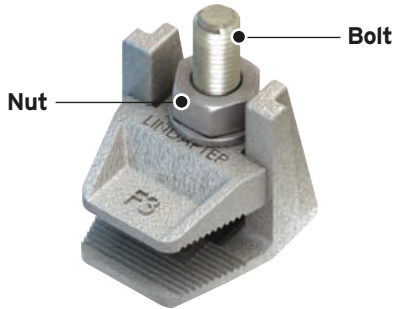
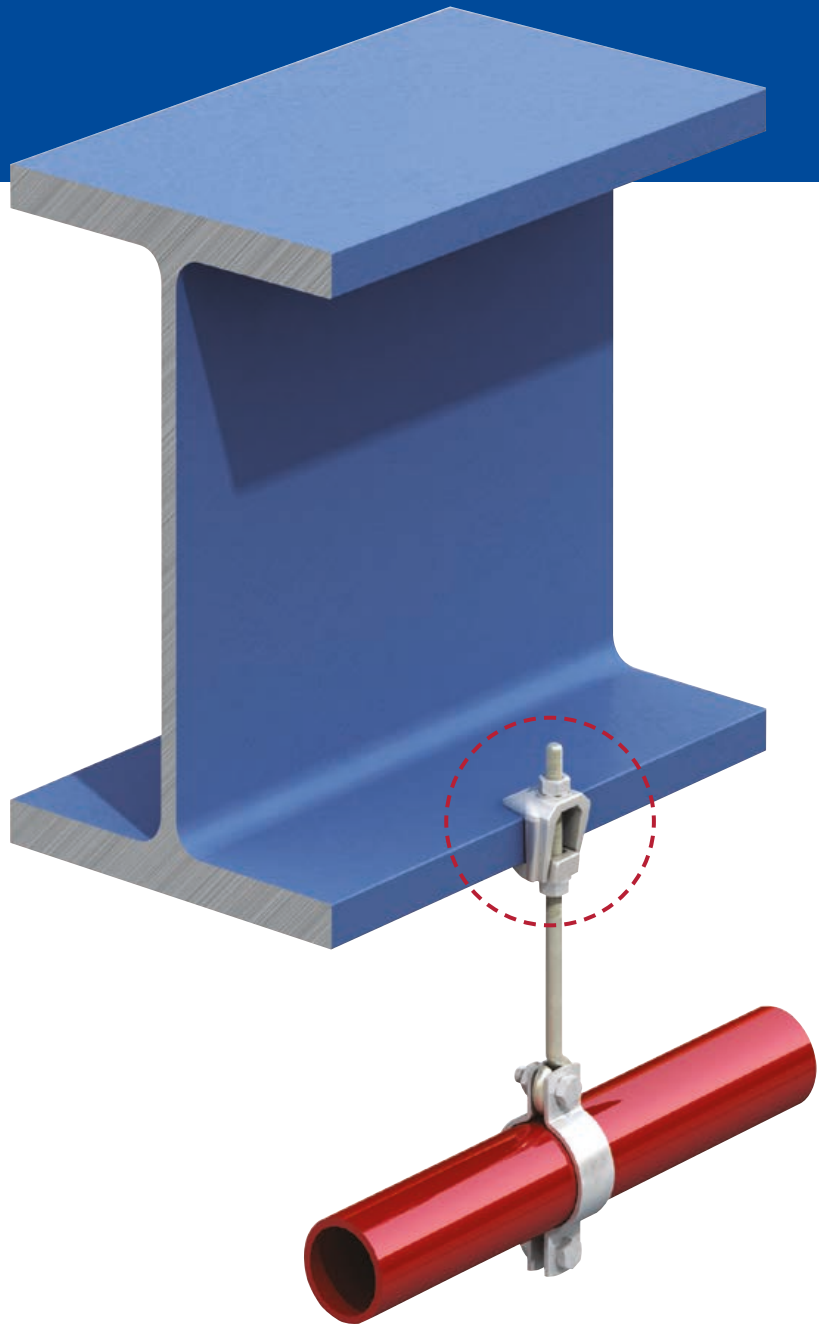

Material: Malleable iron, hot dip galvanized.

Without Bolt Product Code	With Bolt		Safe Working Load (4:1 FOS) Tensile lbs	Clamping Range W	Tightening Torque ft lb	Dimensions				
	Product Code	Bolt Supplied Z				S	T	V	X	Width R
LF3037NB	LF3037WB	M10 (3/8")	270	1/16" - 13/16"	15	7/8"	5/16"	3/8"	1"	1 1/2"
LF3050NB	LF3050WB	M12 (1/2")	450	1/16" - 19/16"	29	1 1/8"	3/8"	1/2"	1 3/8"	1 15/16"
LF3062NB	LF3062WB	M16 (5/8")	900	1/8" - 2 3/16"	69	1 7/16"	1/2"	5/8"	1 13/16"	2 3/8"
LF3075NB	LF3075WB	M20 (3/4")	1350	3/16" - 2 3/4"	130	1 3/4"	9/16"	3/4"	2 3/16"	3"

- ▶ For parallel flanges only.
- ▶ Supplied without bolt or with bolt (contact your local distributor for details / options).